

**COMPETITOR SERIES®**

**C-PP44-HC**

**C-PP67-HC**

**C-PP93-HC**

# PIZZA PREPARATION TABLES

- Beautiful ergonomic construction & rounded corners
- Digital temperature controller and read-out
- All stainless steel exterior and interior
- Forced air refrigeration system
- Side mount compressor for enhanced efficiency
- 19 1/2" deep cutting board included
- Recessed door handles
- Pre-installed casters and shelving
- 90 degree hold open door feature for loading products
- All Natural R290 Hydrocarbon Refrigerant
- US Department of Energy Certified
- Rail accomodates 4" deep pans
- Insulated lids help ensure food products in rail stay cold
- Migali® Protection Plan: 2 Year Parts & Labor Warranty, 5 Years Compressor Warranty

| MODEL     | DOORS | NUM. OF (1/3) SIZE PANS* | CAPACITY CU/FT | SHELVES | H/P  | AMPS | VOLTAGE  | ENERGY CONSUMPTION KWH/24 HR | PLUG TYPE  | TEMP RANGE           | EXTERIOR DIMENSIONS W X D X H** | INTERIOR DIMENSIONS W X D X H | PACKAGED DIMENSIONS W X D X H** | WEIGHT   | PACKAGED WEIGHT |
|-----------|-------|--------------------------|----------------|---------|------|------|----------|------------------------------|------------|----------------------|---------------------------------|-------------------------------|---------------------------------|----------|-----------------|
| C-PP44-HC | 1     | 6                        | 14             | 1       | 1/7+ | 2.3  | 115/60/1 | 1.5                          | Nema 5-15P | +33° F (-)<br>+41° F | 44 x 33 x 43.4                  | 40.4 x 26.4 x 26.3            | 47 x 35 x 46                    | 238 lbs. | 295 lbs.        |
| C-PP67-HC | 2     | 9                        | 20             | 2       | 1/5  | 2.8  | 115/60/1 | 2.1                          | Nema 5-15P | +33° F (-)<br>+41° F | 67 x 33 x 43.4                  | 63.5 x 26.4 x 26.3            | 68 x 35 x 46                    | 335 lbs. | 405 lbs.        |
| C-PP93-HC | 3     | 12                       | 26             | 3       | 1/4+ | 3.1  | 115/60/1 | 2.6                          | Nema 5-15P | +33° F (-)<br>+41° F | 93 x 33 x 43.4                  | 89.4 x 26.4 x 26.3            | 95 x 35 x 46                    | 427 lbs. | 527 lbs.        |

\* Pans are not included

\*\* Height is measured floor to the top of the pan rail and include 6" casters

**FOR COMMERCIAL USE ONLY**

NOTE: MIGALI® RESERVES THE RIGHT TO CHANGE SPECIFICATIONS WITHOUT NOTICE



TOLL FREE: 800.852.5292  
WEB: www.migali.com



# DIMENSIONAL DRAWINGS

C-PP44-HC

C-PP67-HC

C-PP93-HC

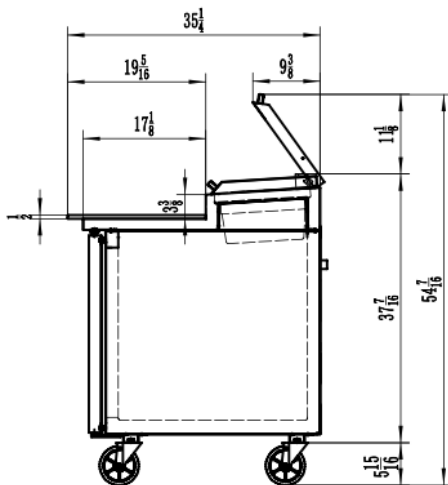
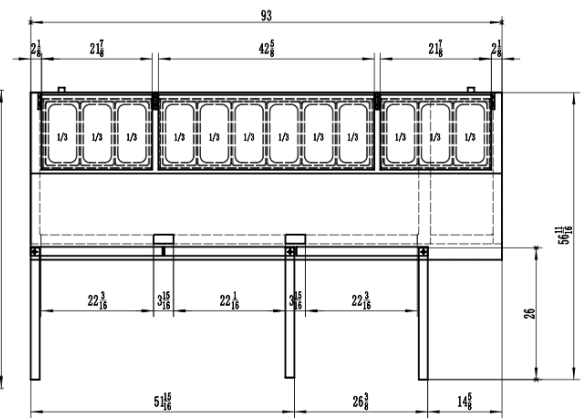
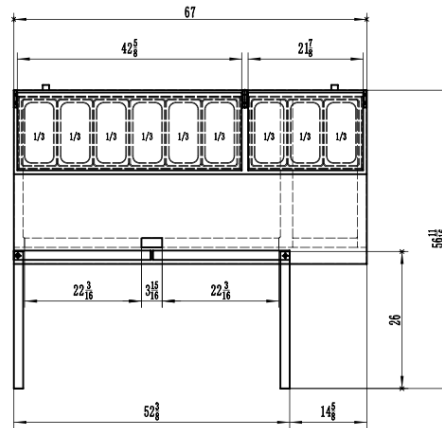
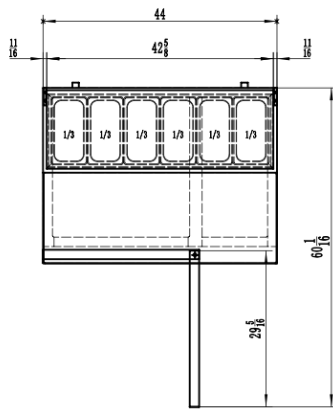
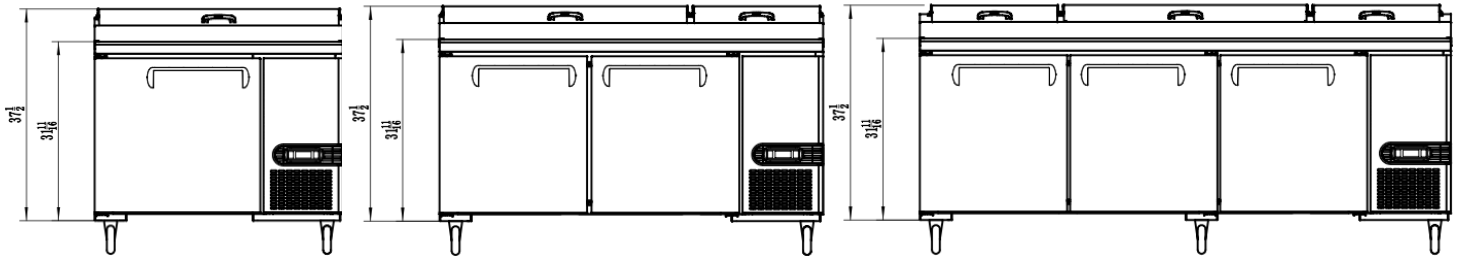

SIDE VIEW (1,2,3) DOOR MODELS



MIGALI® REMAINS AN AMERICAN FAMILY COMPANY SINCE 1955